

# Schriften- und V-Nutfräser

Engraving and V-Grooving

Gravure et rainurage en V

## V-Nutfräser / Gipskartonfräser

V-Groove cutter

Fraise à rainier en V

VGC45L-12

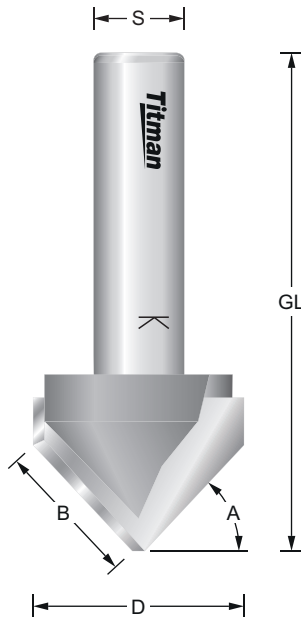

REF.	D mm	A°	L1 mm	L2 mm	B mm	GL mm	S mm	EUR/1
VGC225-8	25	22.5°	5.2	12	13.5	46	8	50,80 €
VGC225-12	25	22.5°	5.2	12	13.5	56	12	50,80 €
VGC30-6	21.5	30°	6.2	12	12	46	6	50,80 €
VGC30-8	21.5	30°	6.2	12	12	46	8	50,80 €
VGC30-12	21.5	30°	6.2	12	12	56	12	50,80 €
VGC45-6	18	45°	9	13	12	46	6	43,44 €
VGC45-8	18	45°	9	13	12	46	8	43,44 €
VGC45-12	18	45°	9	13	12	56	12	43,44 €
VGC45L-8	28	45°	14	18	19	52	8	86,11 €
VGC45L-12	28	45°	14	18	19	62	12	86,11 €
VGC45LK-12	38	45°	19	25	25	67	12	113,80 €
VGC45EL-12	51	45°	25.5	35	35	74	12	139,93 €
VGC60-6	15.8	60°	13.7	16	14	49	6	44,93 €
VGC60-8	15.8	60°	13.7	16	14	49	8	44,93 €
VGC60-12	15.8	60°	20	16	14	59	12	44,93 €
VGC60L-8	23	60°	20	25	23	57	8	60,73 €
VGC60L-12	23	60°	20	25	23	69	12	60,73 €
VGC675-8	15	67.5°	18	23	18	55	8	55,91 €
VGC675-12	15	67.5°	18	23	18	66	12	55,91 €

Ø Fräser/Cutter/Fraise	n.max
1 mm - 25 mm	24.000
26 mm - 50 mm	18.000
51 mm - 75 mm	16.000
76 mm - 100 mm	12.000

V-Nutfräser zum Bearbeiten von Gipskarton, zum Schriftenfräser oder für Ziernuten und Einlegearbeiten sowie Freihand-Verzierungen.

V-groove milling cutter for processing plasterboard, for the font cutter or for ornamental and insert work as well as freehand embellishments.

Fraise à rainures en V pour le traitement de plaques de plâtre, pour la découpe de caractères ou pour le travail décoratif et par insertion, ainsi que pour l'embellissement à main levée.

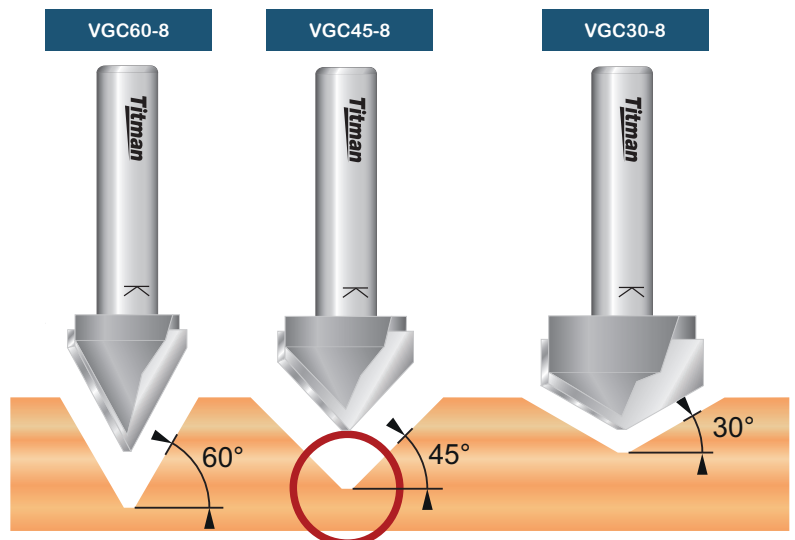

Diese Fräser erzeugen am Grund eine ca. 1 mm breite Gerade.  
These cutters create a straight line of approx. 1 mm at the bottom.  
Fraise créent une ligne droite d'environ 1 mm au bas.

## Fräser für ALUCOBOND DiBOND REYNOBOND usw. auf Seite 21

Cutter for ALUCOBOND DiBOND REYNOBOND etc. on page 21 Fraise pour ALUCOBOND DiBOND REYNOBOND etc. à la page 21

